

The il Leak

February 2025 Minuteman Model A Ford Club Vol 62 Issue 2

The President Speaks:

While looking for suitable photos for this month's Oilleak, I came across some pictures when a few of us participated in a period TV series filming with our Model A's. This was my first time for this sort of activity, but not the first for club members who had participated in other movie shoots. The experience was enlightening and educational in many ways, particularly in terms of the resources and time required to get a few seconds of footage to set a realistic background and time frame. It was also nice to receive payment for something that was great fun to do.

The first photo is me beside my Model A in the role of a parent of one of the girls attending an exclusive private girl's school. The next photo shows Rich Batstone, and Dick O'Brien in chauffeur's costume. Not shown is Matt Cilley who was taking the pictures. What a great un-



expected opportunity that comes with owning a Model A.

After the shooting of the initial episodes of this series, AMC elected to discontinue further production (covid?). At some point the early episodes may air and we will get to see the final product

As a reminder, our February meeting will feature a car show with model cars. My understanding is that Hubleys as well as anything you can carry into the Grange Hall is fair game.

I hope all of you keep busy with your winter projects and prepare for our upcoming events (Swap Meet, Tour Planning, Tune-up Clinic) in the spring, touring in the summer, and New England Meet in the fall. For now, keep active and keep

clicking on the on-line Model A videos. Stay warm.

*Happy Motoring
Harold*



*Happy
Valentine's Day!*



Sunshine

Sue Champagne

No cards were sent out this month.
Glad everyone is starting 2025 healthy.

If you know of a member who needs a little cheering up contact me. sdchampagne1931@gmail.com

Coming Events

(Tours Start at Wayland Town Center RT 20)

- Feb 5** Regular Club Meeting (see page 6)
- Mar 2** MARCOM Flea Market (see page 5)
- Mar 5** Regular Club Meeting
- Mar 23** Minuteman Winter Blahs Flea Market (see page 5)

TL = Tour Leader

Minuteman Model A Ford Club

Treasurer's Report December, 2024

Income:	
Holiday Party	1620.00
<u>Member Dues</u>	<u>140.00</u>
Total Income	\$ 1760.00
Expense:	
Flea Market	36.40
Holiday Party General	2442.28
<u>Oil Leak Printing</u>	<u>80.00</u>
Total Expenses	\$ 2558.68
Net Income	\$ - 798.68



MINUTEMAN HISTORY

by Dick O'Brien

FEBRUARY 1990 35 YEARS AGO

Guest speaker, Rick Knight, of Knight Engineering in Gloucester, MA, held court for at least an hour using a Q & A format. Our thanks went out to Rick for coming to Sudbury and for the invitation to make Kettle Cove Gloucester a tour stop that summer. The first Minuteman charity fundraiser of the year was scheduled for MADD (Mothers Against Drunk Driving) on June 2nd at Spagg's in Shrewsbury, MA.

FEBRUARY 2000 25 YEARS AGO

This February, you would have received in the mail a draft of the By-Laws proposed by the Board of Directors. This was the first revision since 1964, when the club was founded. The March meeting would be dedicated to discussion and approval of the new By-Laws. Marlies presented the MAFCA Chapter Service Award to Jo Johnson in recognition of the Club's appreciation of her efforts over the years.

FEBRUARY 2010 15 YEARS AGO

The MAFCA Service Award was given to someone in the Club who works to better the Club, many times out of the limelight. In 2010 this special award was presented to Nan Linden, who had then supported the Club for 35 years! Not to be outdone by Nan, Doug Linden was once again presented the MAFCA's Certificate of Merit in recognition of exceptional effort and meritorious achievement as editor of the Oil Leak.

National Organizations:



Model A Ford Club of America (mafca.com)
Membership dues \$50/year



Model A Restorers Club (model-a-ford.org)
Membership Dues \$50/year



Model A Ford Foundation (maffi.org)
and the Model A Ford Museum \$35/yr.

2025 Board of Directors

President - Harold Samuels *hsamuels10@gmail.com*

Vice President - Peter McLaughlin *petermclaughlin1485@gmail.com*

Secretary - John Erb *john.erb@verizon.net*

Treasurer - Barbara McElhiney *mcelhiney@rcn.com*

Membership - Nan Linden 508-485-7575 *met59a31@aol.com*

Editor - Doug Linden *douglingen@aol.com*

Steering Committee

Brad Johnson, Rich Batstone, Tom Zappala, Wayne Champagne, Jo Johnson - Emeritus

Tour Director: Don Ross 617-584-5245 *dross02466@gmail.com*

Sunshine: Sue Champagne *sdchampagne1931@gmail.com*

Weekly Breakfast Group →

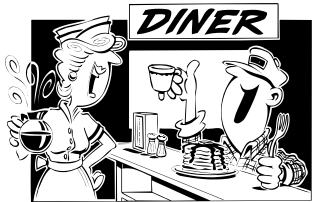

The breakfast group at the Big Apple, 890 Boston Post Road East (RT 20) in Marlborough, MA. We meet every Wednesday

around 7:30 AM. Why not join us there is always room for you. →



Hard luck Trophy



The Hard Luck Award is presented annually to one of our members who has experienced more than his/her fair share of Model A Hardships during the year. This year Don Ross was unanimously chosen to receive this award. Don had a some minor electrical and carb issues during the season, but those were not the reason. While attending the NE Meet in September Don was on the grand tour and at the first stop he noticed his front spring was broken. Fortunately this happened at Wayne Carini's restoration shop where the repair was eventually completed. Congratulation Don



*"Nothing is particularly hard if you divide it into small jobs."
Henry Ford*

Secretary's Report

Minutes of the Minuteman Model A Ford Club January 8, 2025

Sudbury Grange Hall, Sudbury, MA

The meeting was called to order at 7:29 by outgoing president Brad with 29 members in attendance. A gavel and applause were given to the new president Harold Samuels. A plaque was also given with all the past presidents listed.

Member Dennis Porter made plaques with gavels to present to the presidents. President Samuels presented a gavel plaque to outgoing president Brad Johnson.

President Samuels then led the members in the pledge of allegiance. He listed the new officers: The vice president is in the Bahamas and the treasurer is in Florida. The new secretary Erb was present as was Don Ross, tour chair; Nan Linden, membership chair; Doug Linden, newsletter editor and the steering committee was listed in the Oil leak.

Announcements; Tom Zappala reported on the progress of next year's New England Meet. He is making good progress in selling ads in the program and some raffle items are already in. The rooms in the Boxborough Regency are already sold out and there are rooms blocked in the Westford Regency and the Marriot. Meals for the meet are being planned. A disc jockey is lined up for Friday night and a Beatles Tribute band is on board for Saturday night. The Grand Tour will go to Kimballs Farm and travel through Apple country. Meet clothing and judging is still in progress.

Nan Linden reported there were no new members.

Doug Linden reported on National news: He attended the national awards banquet in Salt Lake City where there were interesting tours. The next national event is the MARC membership meeting in Nashville, IN. Doug and Nan received the Volunteer of the Year at the Awards banquet and Doug is back on the national board as Chapter coordinator. President Harold announce that Doug also received a newsletter award from MAFCA director William Langford.

Don Ross spoke on tours: He is looking for tour ideas for next year and is planning a meeting in March. He reported that tours this season went well with the usual electrical, out of gas and welded lug problems to solve. President Harold congratulated Don for his work and presented him with the hard luck trophy earned because of his broken spring in CT.

Larry Conley spoke of his restoration of a sport coupe hoping for help with the interior and he will also be

making license plate toppers for those interested and gave a list of parts he has for sale.

The treasures report was accepted as printed.

New Business: upcoming events: tour meeting, the NE meet needs a repair tent captain and eventually other volunteers will be needed for parking, raffle etc.

President Samuels announced the Celebration Cake will be devoured at the break.



Doug Linden reported that next month's meeting would be a "car show" of Hubley models and any other manufacturer of models. He also reported that member Gary Hoyt wants to sell his beautifully restored 1964 Thunderbird for \$18,000. Also, there will be a program at the Public house on the country tour of a model T in 1923.

Rich Batstone spoke on raffle items. The items at the Connecticut meet were impressive and he and his wife Linda showed some items for the raffle they are collecting and encouraged all members to start collecting raffle items for our NE meet.

Craig martin reported that the flea market would be March 23 at the Maynard Elks with admission fee being raised from 3 to 5 dollars. Raffle items would be needed for the event.

It was reported that Dick Krug would be running the 50/50 raffle at the break and cake and coffee would be available.

A motion to adjourn was made and seconded at 8:08 PM

Respectfully Submitted,

John Erb

Secretary

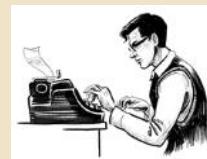



Harold Samuels, 2025 President, presents 2024 Brad Johnson with a ceremonial gavel as a token of our appreciation. Thanks also go to Dennis Porter for creating the amazing plaque.



Harold Samuels presents newsletter editor Doug Linden with a the MAFCA Newsletter of Distinction Award.

Sunday March 23, 2025

7:30 AM - 11:30 AM

Maynard Elks Lodge
34 Powder Mill Road (RT 62)
Maynard, MA 01754
Vendor Spaces: \$20.00
General Admission: \$5.00
Craig Martin (978-562-2390)

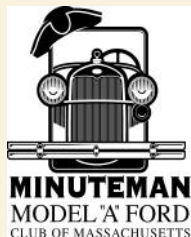

License Plate Toppers



Larry Conley is going to make a small batch of the club's license plate toppers. These are made of 16 gauge stamped steel, black powder coated, with a UV Minuteman sticker.

Call or text Larry at 603-6899-3634 if you would like to get one at the next meeting.

MARCOM FLEA MARKET

SUNDAY- MARCH 2nd

WINTER FLEA MARKET

**AT HOLMES TRANSPORTATION COMPANY
22 MYRTLE STREET, NORFOLK, MA.
FROM 7:30 AM TO 11:00 AM Admission**

\$5.00

Contact Dean Zwicker (508-285-3211) for Vendor Space @ \$20 each



Time to renew your **MEMBERSHIP**
Dues are Due



Have you paid your 2025 dues?

In order for us to keep our records up to date, **PLEASE** complete the form below and return with your check for **\$20**. If there are no changes, you won't have to complete the entire form, just check the appropriate box. *Thank you.*

Membership Renewal: _____ or New: _____

First Name _____ Last Name _____

Spouse/Significant Other Name _____

Street _____

City _____ State _____ Zip Code _____

email _____ Telephone ____ - ____ - _____

If No Changes above check here: _____

I would like to receive my **Oil Leak** by email. Yes _____ No _____

(If you do not specify, it will be sent electronically if we have an email address on file.)

Are You a member of MAFFI _____ MAFCA _____ MARC _____

Model A Info:

Year _____ Body Style _____ Year Acquired _____

Year _____ Body Style _____ Year Acquired _____

Please make check payable to: Minuteman Model A Ford Club and mail to

Minuteman Model A Club
P.O. Box 545
Sudbury, MA 01776

“Artie - Fact”

D'oh



I didn't realize how bad of a driver I was until my sat nav said, "In 400 feet, do a slight right, stop, and let me out."

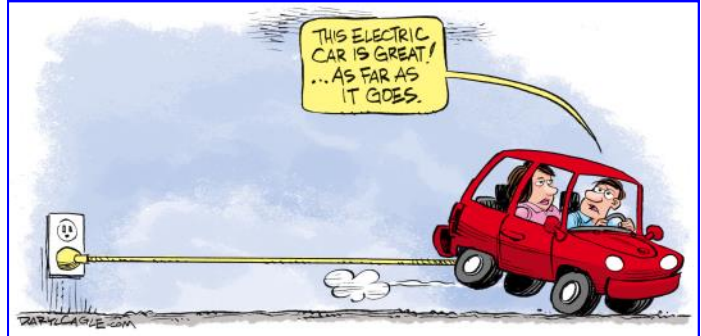

For Sale 1964 Thunderbird

Long time member, Gary Hoyt, is thinning his collection. Gary is listing his beautiful 1964 Thunderbird Coupe. Color is Seafoam Green with light green interior. Only 45K Miles. Fully restored and runs great. Asking \$18K

Contact Gary Hoyt 508-655-0077



Note: This is not a picture of Gary's T-Bird, however it does look exactly like this one.

CMARC TRIVIA QUIZ

1. Name a type a tire other than radial.
2. What was the old school way of navigation before GPS?
3. What is a popular anti-theft device?
4. What is a gasoline maker ?
5. What engine component's have heat ranges?
6. How would someone customize a car roof?
7. What company manufactured the international scout?
8. What auto company manufactured the Metropolitan?
9. What year did civilian auto production resume after world war II?
10. Which two American auto companies produced the 428 cubic in. motor in 1962?



Happy Valentine's Day

S T V A L E N T I N E S DAY FEB 14

Roses are red
Violets are blue
she is expecting flowers from you



Say it with
FLOWERS!

NATIONAL FLOWER SHOW—MINNEAPOLIS—MARCH 29 to APRIL 6

Elizabeth Arden's Presents the World's Most Beautiful Girl named at the Flower Photograph Division Association.
 Look for the emblem of the Society of American Florists, 11 to 13th St. in Grand Haven.

She hasn't said a word—hasn't dropped a hint—but just the same you know that February fourteenth and *flowers* naturally belong together. And what fun it is to see the sparkle in her eyes when they behold your gracious gift. Remember that date! You know she isn't going to forget!



Flowers have been the #1 way to say Happy Valentine's Day as you can see in this 1930 ad in Collier's Magazine. Not much has changed over the years so don't forget February 14th, it's just around the corner.

DIFFERENCE IN HUBS

Three different types of hubs have been used with the A-1115-B rear hub and brake drum assembly. See Fig. 765.

The "shoulder shank" design is distinguished by a shoulder located midway on the shank.

The taper shank type is practically the same as the shoulder shank design except that the shank is tapered from the shoulder to the outer end.

The grooved shank design is distinguished by a groove located midway on the shank.

These hubs are all interchangeable. However in so far as stocks permit dealers should use the same design hub on both wheels. In the future only the grooved design hub will be supplied.

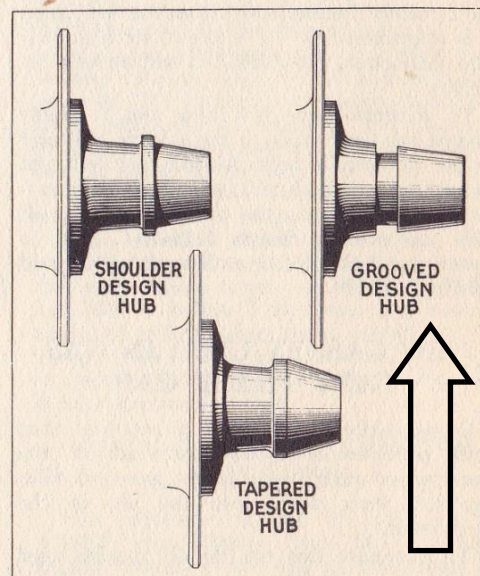

Fig. 765

ANSWERS TO CMARC TRIVIA QUIZ

1. Bias-ply
2. A road map
3. Alarm system
4. A refinery
5. Spark plugs
6. Chop the top
7. International Harvester
8. AMC
9. 1945
10. Ford and General Motors



NEW Advertiser

Fundamentals First Fund

Symbol: KNOW

**Your money
Carefully managed**

The Fundamentals First Fund, an ETF, is part owner of approximately 100 publicly traded worthy companies and owns publicly traded debt. We have been individually selecting companies with care for over three decades as Mason Capital Partners. If you are interested, read on via our website at

www.FundamentalsFirstFund.com

Mason Capital was founded by Model A member Al Mason (1931 Fodor)

2/21/24 IPO Market Open: \$10.00
 12/31/24 Market Close: \$10.72
 Dividends Paid: \$ 0.14

Investors should consider the investment objectives, risks, charges and expenses carefully before investing. For a prospectus or summary prospectus with this and other information about the Fund, please call 617-228-5190 or visit our website at www.fundamentalsfirstfund.com

*Investments involve risk. Principal loss is possible.
 Quasar Distributors LLC.*

Support Our Sponsors



The Big Apple restaurant



(508)229-2829

www.bigapplerestaurant.net

890 Boston Post Road E
 Marlborough - MA

EST. 1840

H.H. WARREN INSURANCE AGENCY, INC.

22 GLEASONDALE ROAD STOW, MA 01775

jsmith@hhwarreninsurance.com

JEFFERY SMITH
 President

Tele: (978) 897-7074
 Fax: (978) 897-9320

STONEWALL

insurance group inc.

We work with all of the top insurance companies to find you the best coverage for the best price.



Jeff DeMarey
 (413) 514-0469

THE BEST CARS DESERVE THE BEST INSURANCE.

stonewallinsurancegroup.com

Mike's "A" Ford-able Parts

Mike Butcher



124 Model A Drive, Maysville, GA 30558

email: mike@mikes-afordable.com - www.mikes-afordable.com

Fax: 706 652 2492 - Phone: 706 652 3866

1 888 TRY MIKE (879 6453)



Specialising in 1928 - 1931 Model A Ford Parts

Class "A" Advertisers



Thomas J. Dyer, CPFA
 Wealth Manager
 354 W. Boylston St., Suite 231
 West Boylston, MA 01583

978 264 1906 office
 855 330 3679 fax
 tdyer@pwfgllc.com
 www.pwfgllc.com

Securities and Advisory Services offered through LPL Financial, a Registered Investment Advisor. Member FINRA/SIPC.



Specializing in Ford Model A & T repair and restoration.

Ryan Thibeault
 Owner
 67 Old Wakefield Rd
 Milton, NH 03851
 603-652-8609
 tebobarn@gmail.com



RUSMART
 AUTO UPHOLSTERY

723 MAIN STREET (RTE. 12), NORTH OXFORD, MA 01537

Ken & Art Clements (508) 987-1171

CUSTOMS
 ANTIQUE
 BOATS
 RV'S

Mm MITCHELL MANUFACTURING



Steve & Cyndi Mitchell
 Mitchell MFG.

530-458-4500 800-859-2088
 www.mitchelloverdrivemfg.com
 mitchmanfc@frontiernet.net

MODEL A FORD
 SYNCHRONIZED-TRANSMISSION FORD OVERDRIVES/UNDERDRIVES
 VINTAGE CAR OVERDRIVES 1928-1948

P.O. Box 925 1157 Parker St. Colusa, CA 95932



**CENTRAL MASS
 POWDER COATING**

It's all in the details

32 Greeley St Clinton MA 01510 (978) 365-1700
 info@CentralMassPowderCoating.com
 www.CentralMassPowderCoating.com



TAM'S MODEL "A" PARTS
 42 TEMPLE STREET
 WEST BOYLSTON, MA 01583

Tel: (508) 835-9292
 (800) A-PARTS-1
 Fax: (508) 835-9199



www.modelaparts.com
 email: tamsforda@aol.com

EVERYTHING FROM A TO T!



FREE CATALOG
 \$10.00 Outside the U.S.



888-262-5712
 snydersantiqueauto.com

THE WORLD'S LARGEST SUPPLIER OF 1909-31 FORD PARTS!



800-255-1929 or www.brattons.com
 1606 Black Acre Circle, Mount Airy, MD 21771

Send for a free 194-page illustrated Model A Catalog with over 3,900 Model A parts, with full descriptions & illustrations—over 90% are U.S. made.

Meeting News

Don't forget the winter model car show is the main entertainment at the February meeting.

This should be a fun event.

Planning for the NE Meet continues and an update will be made at the meeting.

If you haven't paid your dues please make sure you send it in before you are taken off the mailing list.



Our Monthly meetings are held at the Sudbury Grange Hall, 326 Concord Rd in Sudbury. Meetings start at 7:30 PM. Hope to see everyone there.

Be Sure to visit www.oilleak.org

**MINUTEMAN
MODEL "A" FORD
CLUB OF MASSACHUSETTS**



**Please
Mail to:**

February 2025

**Minuteman Model "A" Ford Club
PO Box 545, Sudbury, MA 01776**